



BCS-2000 and 3000 Ducted Evaporator Install

SUPPLIES NEEDED FOR INSTALLATION

1. 3/8" AND 3/4" copper tubing (2000) OR 3/8" AND 7/8" copper tubing (3000). Tees of each size
2. 1/4" copper water supply and saddle valve
3. 1/4" condensate vinyl drain tube/tube clamps
4. Provide 120v 30A circuit for indoor evaporator, and 230v for outdoor condensing unit. Check local codes.
5. 18-2 stat wire; to be used to extend temperature sensor, humidity sensor cable, keyboard, and master to slave control jumper.
6. Condensing unit pad

CONDENSING UNIT SET UP

1. Place unit on a firm level location (pad) for outdoor applications, or add 4 anti-vibration pads to each corner of the condensing unit for indoor use. Place in an area with adequate ventilation.
2. Braze in suction and liquid lines to condensing unit.

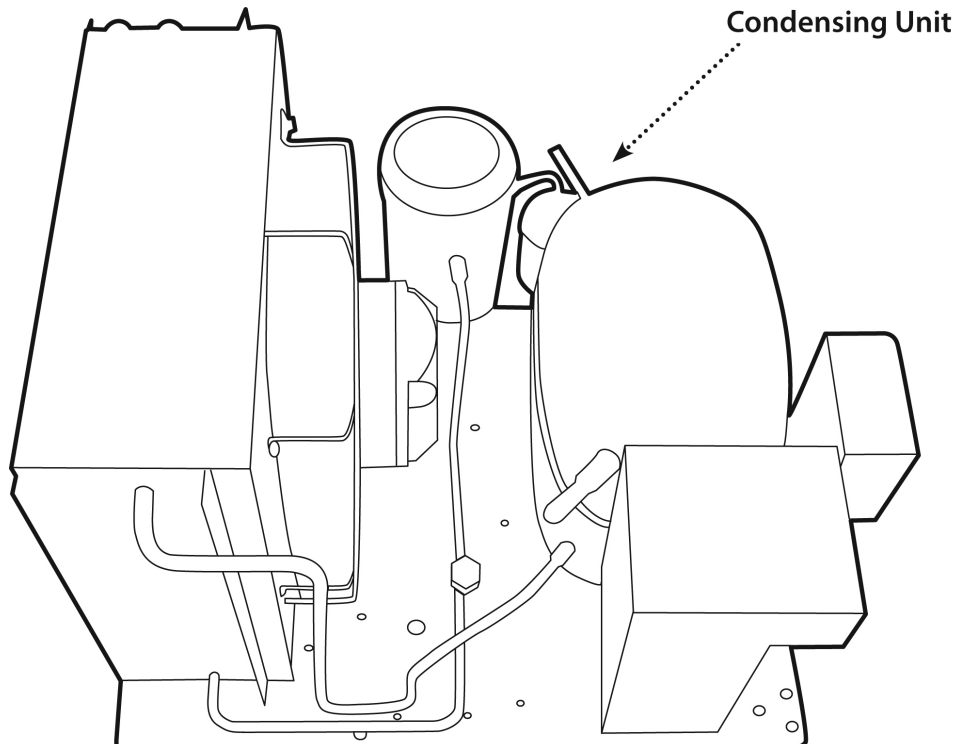

CONDENSING UNIT SET UP, continued

3. Bring 3/8" copper tubing from the liquid line of the condensing unit to a spot equidistant to both evaporators and solder that line into the run side of a 3/8" x 3/8" x 3/8" tee.
4. Braze both the 3/8" line to the liquid line of each evaporator from the run and branch of the tee.
5. Repeat the same procedure from the suction line of the condensing unit. Suction line sizes are 3/4" for 2000, 7/8" for 3000
6. Power from disconnect (recommended) 12-2/with ground to the condensing unit.
7. Set electronic controller for the correct 20 psi cut in, 5 psi cut out

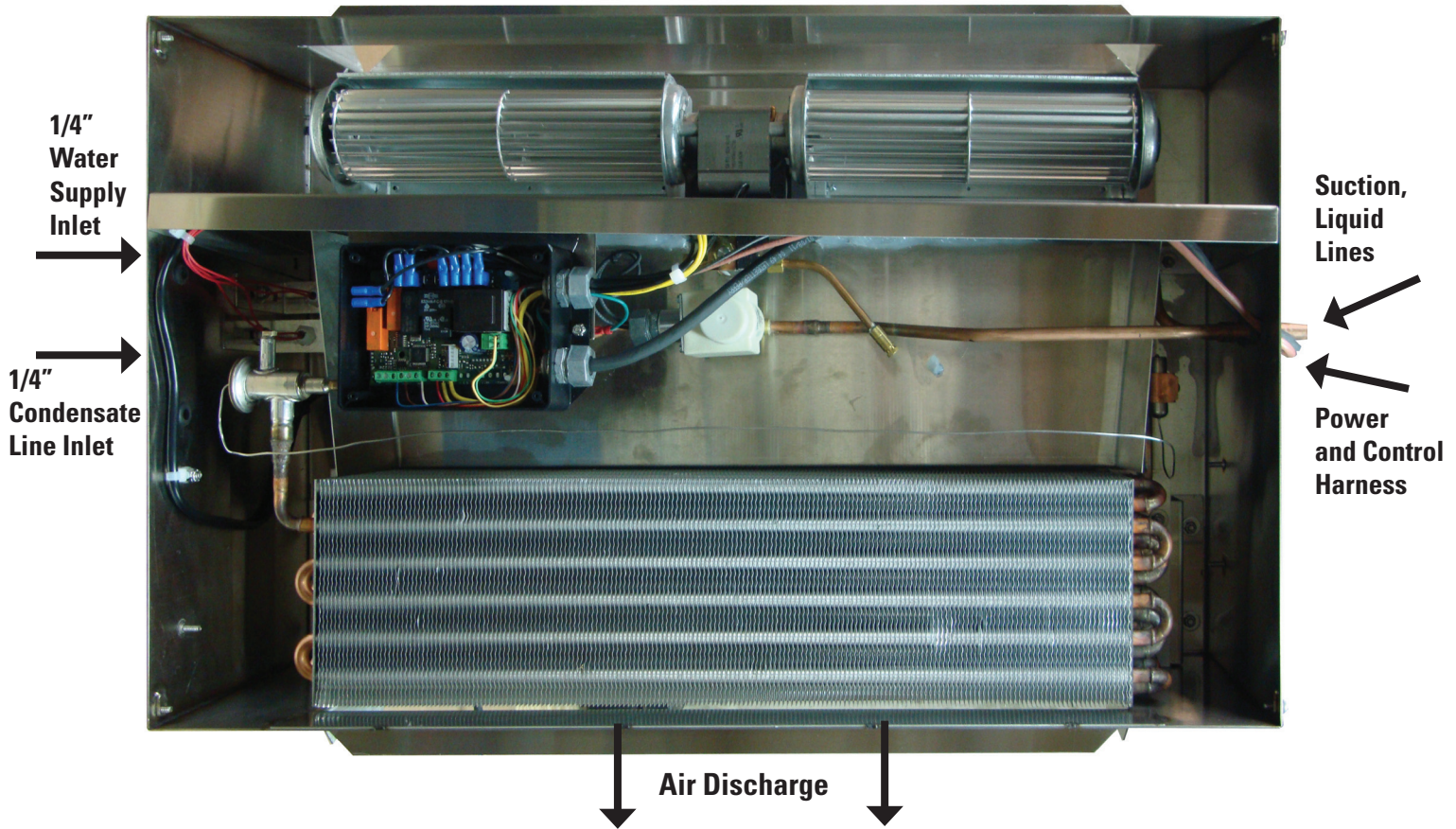

EVAPORATOR SET UP

1. Locate a suitable location, and allow enough room for supply and return transitions
2. Run the 1/4" drain line from the pump in the evaporators and out to a suitable location. Heat tape any portion susceptible to freezing. Maximum lift 8 ft vertical or 50 ft horizontal run. Pitch drainline downhill.
3. Attach 5-1/2" x 20" sheet metal flange to each evaporator on supply (coil side) and duct to the supply grille as high and as close to the middle of the room as possible. Accordingly, attach a 4" x 24" sheet metal flange to the fan side of the evaporators and duct to a low mid point return grille.
4. Below is the BCS electronic control package used in both the BCS2000 and BCS3000 System. The main control module below must be mounted equidistantly between both evaporators in a serviceable location.

Master Control Module



5. The first port on the left includes two pieces of 18-2 that should be connected to each slave module in both evaporators at #1 and #2 terminals. These connections will shut down the system if there is ever a high water condition in either evaporator. They are connected in parallel to each safety float. In the first port there is a piece of 18-6 that is color coded per our standard operating instructions to be affixed to the VH620 Keyboard Display, the temp sensor, and the humidity sensor (see Page 6 in "Power To the Evaporator"). Second port from the left is power, 14-2 with ground, 115V. The third and fourth outlets hold each 14-6 jumper cable that is also color-coded. These run to each evaporator slave module inside of each stainless steel enclosure.
6. Make sure that the unit is covered tightly with each cover and the edge of the cover is sealed with silicone.

Slave Control Module

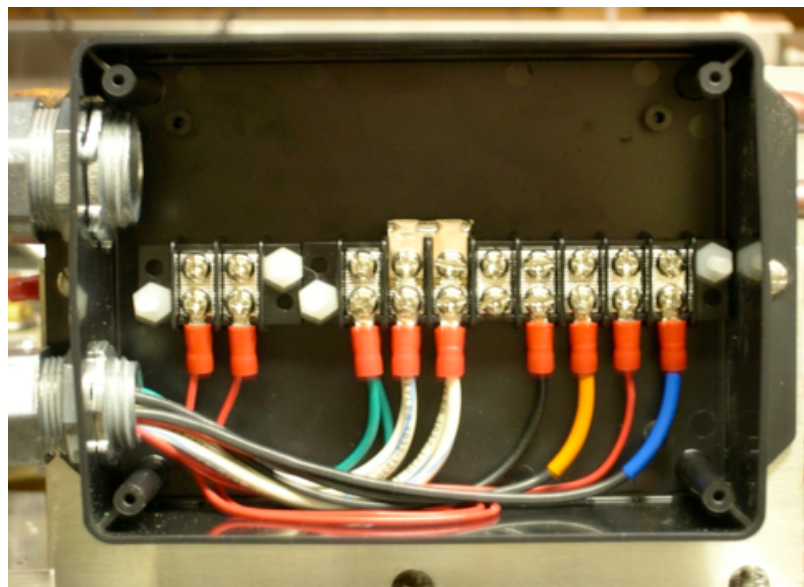

7. From left to right, the first two terminals should be connected to the 18-2 leads from port one in the master control module. Terminals 3, 4, 5 (one white lead), 7, 8, 9 and 10 will be connected to each color coded lead from the 14-6 cable that you run from the Master Control Module. Replace the cover firmly and seal perimeter with silicone.

EVAPORATOR SET UP, CONTINUED

8. Wrap the TXV and refrigerant solenoid with ESP heat block (#HB34) or comparable product. Braze the refrigerant solenoid tubing to the liquid line. Remove the txv bulb and braze in the suction line to the line exiting the evaporator. Re-attach the bulb when cool.

Water Solenoid Connection

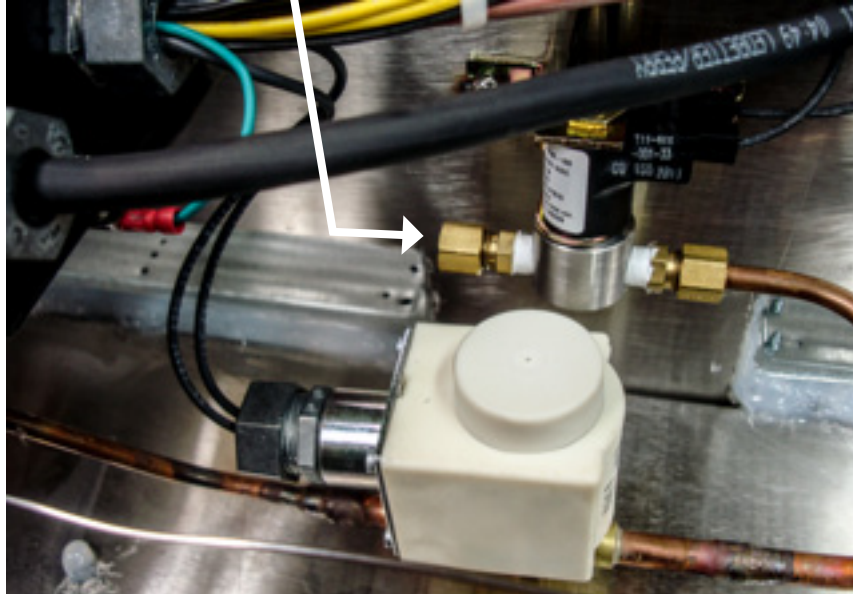

9. Locate the nearest water supply. Use a saddle valve with compression fitting connections. Connect the water filter to the fitting. Run 1/4" copper from the filter and attach to the water solenoid inlet in each evaporator.

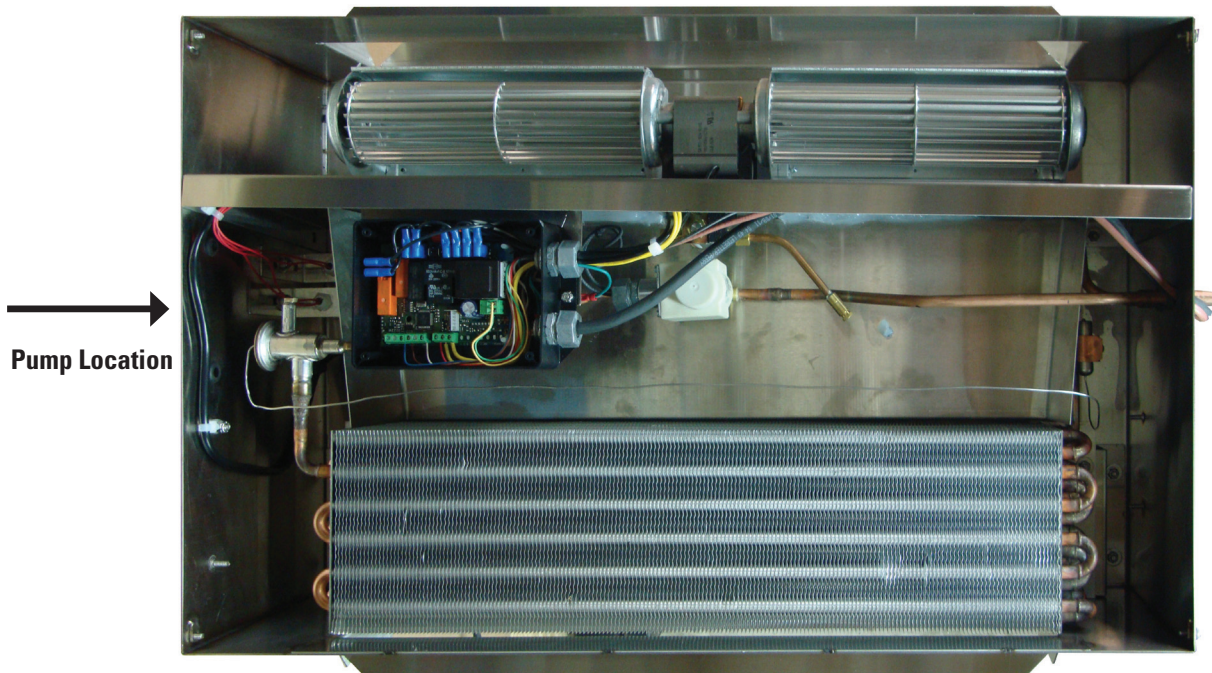

10 Attach the 1/4" vinyl hose drain tube to the outlet of the condensate pump in each evaporator. 11 For indoor applications, run 1/4" vinyl condensate drain tube from the pump to a suitable location 12. Do not replace cover until unit test is complete.

CONTROLLER DISPLAY SET UP

1. Install double gang box and cut out a blank plate to accept the Bacchus Temp/Humidity Keyboard (VH620). A stainless steel plate is available. See wiring diagram on the next page. The keyboard can be mounted inside or outside of the room. Run 18-2 stat wire from the monitor back to the evaporator above the ceiling opening, and attach to the yellow and green lead wires indicated. The keyboard can be mounted up to 75 feet from the microprocessor inside the evaporator.
2. Mount the humidity sensor (XH10P) to a discreet side wall location @ 6ft. from the floor. Bring the two lead wires from the sensor, and attach to the + and – lead wires indicated. White lead to the #2 terminal, and Red lead to the #1 terminal on the sensor. **Do not mount in the air discharge (coil side) of the evaporator. Polarity sensitive.**
3. Mount the temp sensor adjacent to the humidity sensor, and run the lead wires back to the wire harness. It is best to place both sensors in a location where they cannot be touched by the end user, and are not in the air discharge of the evaporator.
4. Check supply voltage before connecting to the controller/power board.
5. Do not expose to water or moisture: use the controller only within the operating limits avoiding sudden temperature changes with high atmospheric humidity to prevent formation of condensation.
6. **Warning: disconnect all electrical connections before performing any kind of maintenance**
7. Ensure that the wires for probes, leads and the power supply are separated and are not intertwined or crossed.
8. The microprocessor has been preprogrammed for 55F° and 50% RH. To change either setting:
 - A. Push the Temp or Humidity set key for 3 seconds and release
 - B. Use the up^ and down v keys to change the value
9. There is no reason to change temperature or humidity set point depending upon the end users preference.
10. **IMPORTANT.** If actual humidity is above set point (and it often is during start up), the system will go into de-humidification mode. Humidity setting is over-riding temperature setting. The unit will pull down below temperature set point. This is short term and is fixed
be resetting humidity set point to actual, or a point slightly above. After the system equalizes out, this can be reset to a lower preferred setting.

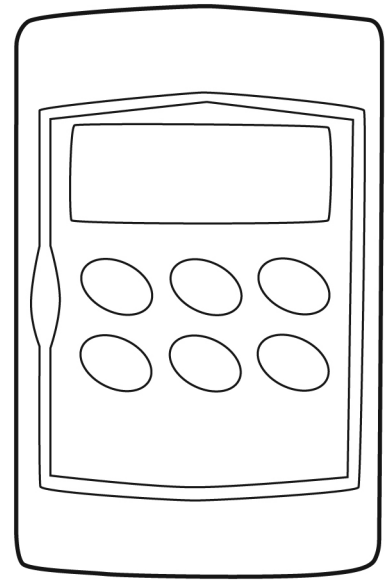

VH620 Keyboard

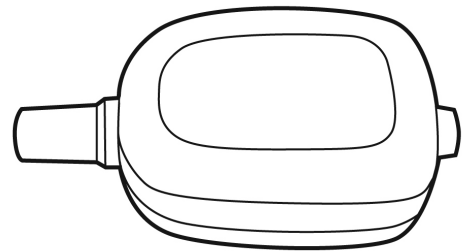

XH10P Humidity Sensor

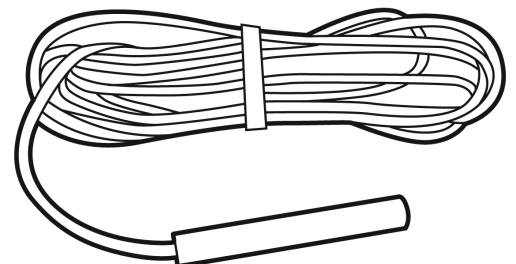

18NBI

5. Alarm Signaling

Message	Cause	outputs
"P1"	Thermostat probe failure	compressor and heating outputs off (on dehumidification system only)
"P3"	Humidity probe failure	humidity regulation off
"HA"	High temp alarm	outputs unchanged
"LA"	Low temperature alarm	outputs unchanged
"HHA"	High humidity alarm	outputs unchanged
"HLA"	Low humidity alarm	outputs unchanged

In the instance of any of these alarms, call Bacchus Tech Services, or your installation contractor

POWER TO THE EVAPORATOR

1. Bring in 14-2 conductor wire with ground to the evaporator, and connect to the 14-2 with ground wire harness exiting the evaporator. Make sure the line has adequate amp rating for the circuit.

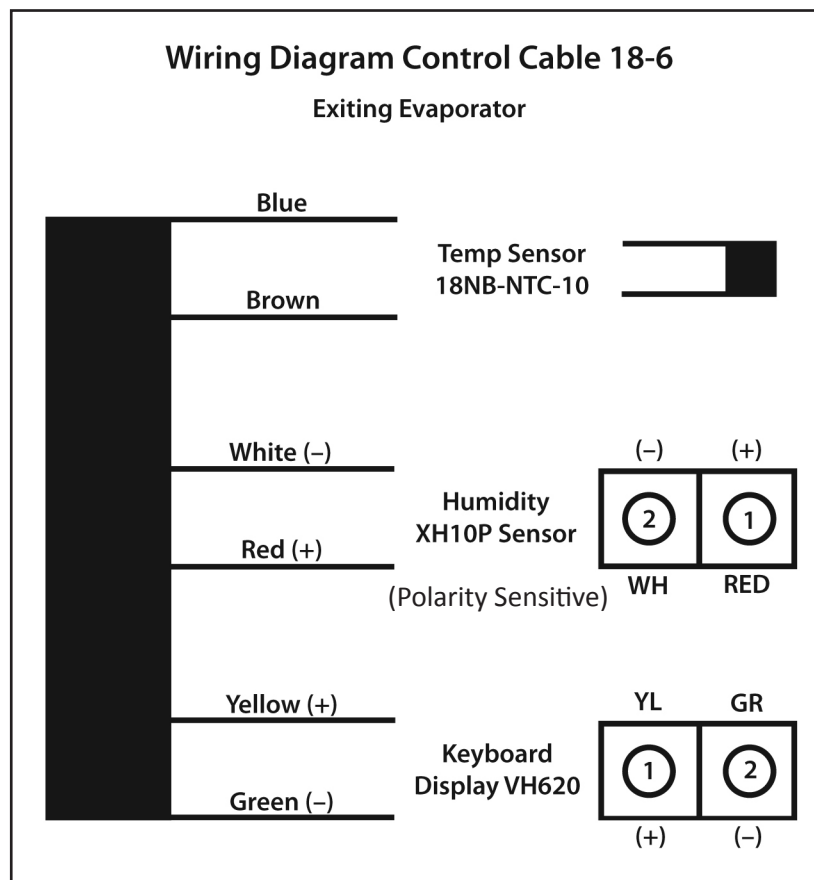
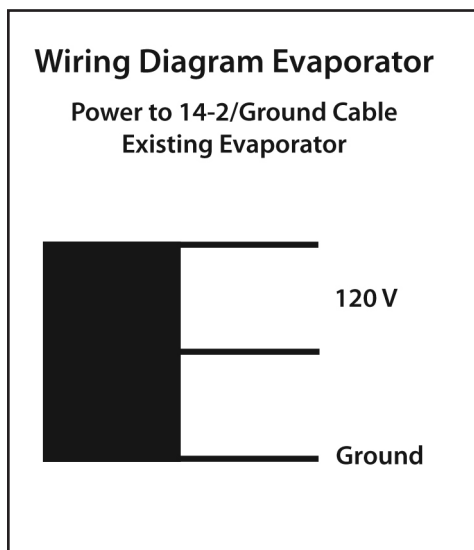

CHARGING THE SYSTEM

1. Evacuate and pressure test the system. This can be accomplished by charging with nitrogen to 75 lbs and checking your gauges for any sign of a leak. Evacuate the system to 500 microns.
2. Charge the system with R134A until the sight glass goes clear. Initial charge will be 7.5 pounds of 134A; the pumpdown capacity of the receiver. It is very important not to over charge this system. As soon as the bubbles in the sight glass disappear, discontinue charging. Over-charge will result in an ice block in the evaporator.
3. System Start up. Before replacing stainless steel enclosure cover, power up the system to make sure water solenoid is opening correctly. The misting nozzle will be open. Remove power and replace the cover. Power up the evaporator, and let the system pull down. At temp set point the refrigerant solenoid will close and the system will pump down and shut off the condensing unit.
4. Check level of safety float.
5. Breakers. We recommend a fused disconnect.

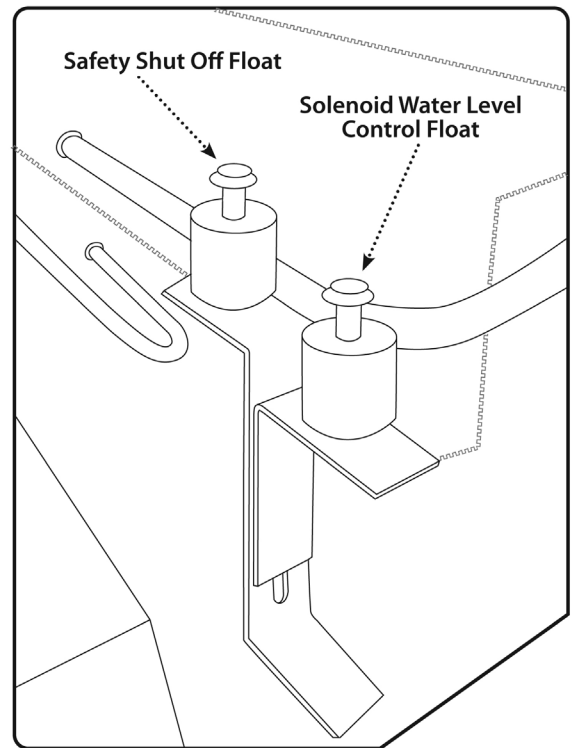

MAINTENANCE AND TROUBLESHOOTING

Have your system checked each year by a certified refrigeration technician.

He should:

1. Clean the indoor and outdoor coils
2. Change the water filter on the Humidification models, and change out the humidification mister head
3. Drain the stainless steel sump and clean it if necessary. This will prevent any possible mold build up.
4. Check the operation of the condensate pump, and make sure the water misting fitting is operating properly, by allowing water to flow thru it. Clean with vinegar if clogged and change the water filter.
5. Check the electronic controller for any alarm conditions
6. Check the refrigerant level and system operating pressures.
7. Clean the water solenoid on a yearly basis, and replace every two years.

Warning: If the water solenoid sticks open, overflow can result.



TROUBLESHOOTING

Alarm conditions on the electronic controller Call BCS Tech Services at 937-665-0424

Unit will not reach temperature	Call your installation contractor to Determine proper refrigerant charge. Dirty condenser?
Unit has shut off	Call BSC tech services or field Service; could be bad Compressor, fans, controller or Pump

ALARM SIGNALING		
Message	Cause	Outputs
"P1"	Thermostat probe failure	compressor and heating outputs off (on dehumidification system only)
"P3"	Humidity probe failure	humidity regulation off
"HA"	High temp alarm	outputs unchanged
"LA"	Low temperature alarm	outputs unchanged
"HHA"	High humidity alarm	outputs unchanged
"HLA"	Low humidity alarm	outputs unchanged

In the instance of any of these alarms, call Bacchus Tech Services, or your local service contractor

	BCS-2000 CONDENSING UNIT	BCS-3000 CONDENSING UNIT	BCS-2000 EVAP	BCS-3000 EVAP
Dimensions	24"D x 17.1"W x 16.7"H	24.1" D x 18.3"W x 16.6"H	18"D x 29.25"W x 6.5"H (x2)	18"D x 29.25"W x 6.5"H (x2)
Weight (net)	103 lbs	112 lbs	49 lbs (x2)	49 lbs (x2)
Liquid Line	3/8"	3/8"	3/8"	3/8"
Suction Line	3/4"	7/8"	1/2"	1/2"
Electrical	208/230 V	208/230 V	120V	120V
Cond. Unit MFS	25A	40A		
Cond. Unit mca	16.9 A	23.9 A		
BTU capacity 25F suc, 90F amb	7980	12600		
Refrigerant	134A	134A	134A	134A
Water Supply Connection			1/4" compression	1/4" compression
Condensate Connection			1/4" mpt	1/4" mpt
Evap Circuit Breaker Size			30 A	30 A



Phone: 937-665-0424

Fax: 937-890-6664

REFRIGERANT AND ELECTRICAL CONNECTIONS

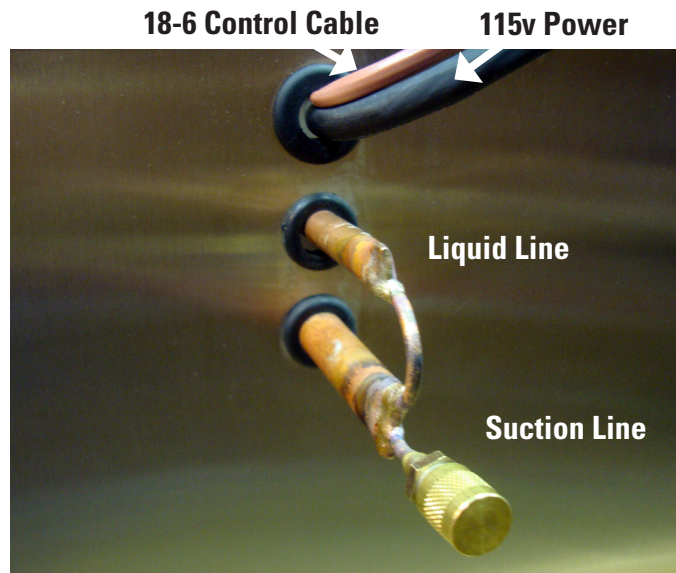

Phone: 937-665-0424
Fax: 937-890-6664